

LOOSE FURNITURE [BUFFET]
CENTRED ON WALL
1500Wx400Dx750H

P-01 PLAN - FLOATING SHELVES
Scale 1:20 @ A3

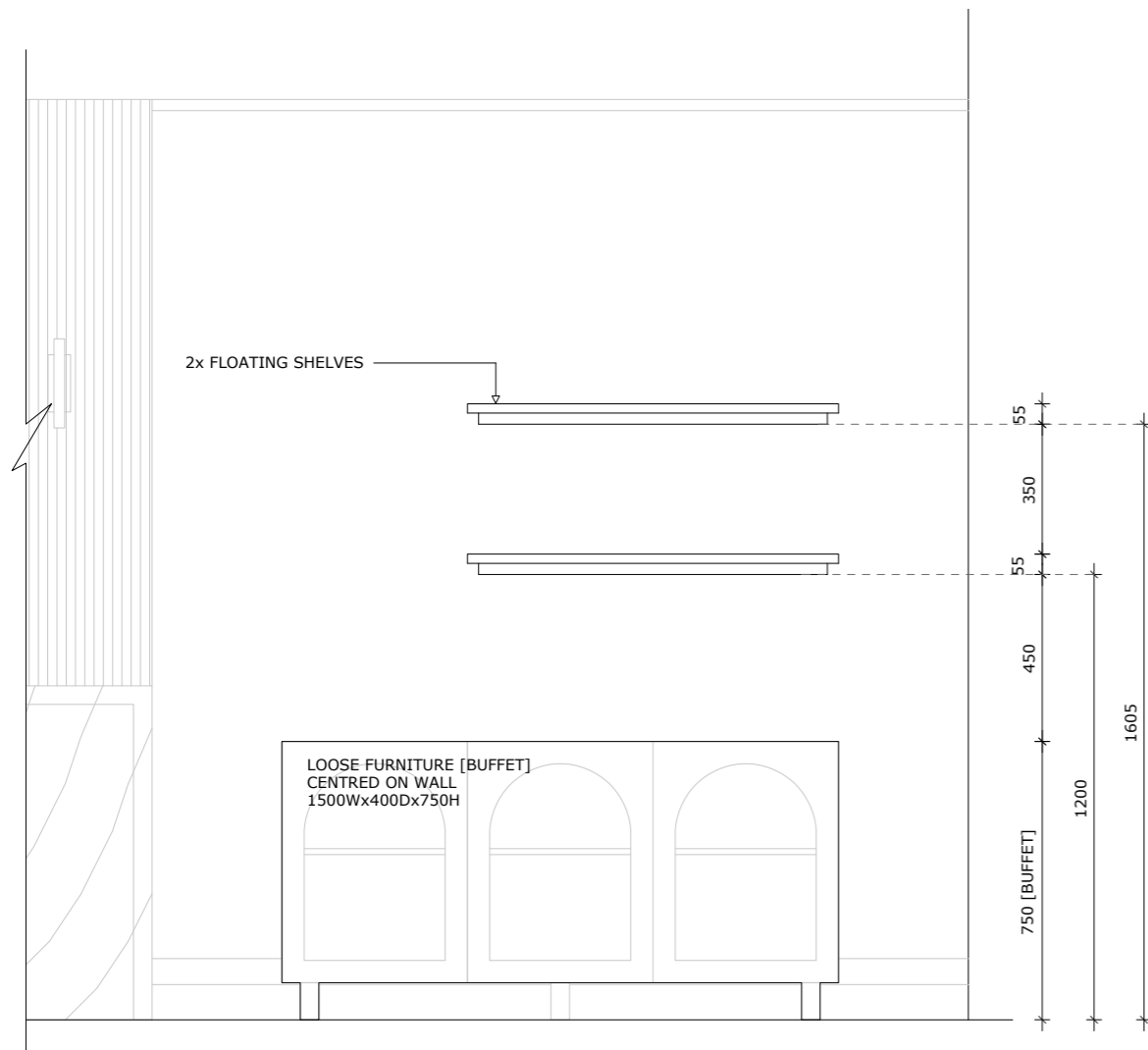

2x FLOATING SHELVES

LOOSE FURNITURE [BUFFET]
CENTRED ON WALL
1500Wx400Dx750H

E-01 ELEVATION 01 - FLOATING SHELVES
A160 Scale 1:20 @ A3

30mm THICKNESS FOR
ALLOWANCE OF STEEL
SUPPORT WITHIN.
JOINER TO CONFIRM
REQUIREMENTS FOR BEST
SUPPORT, DESIGNER
APPROVAL REQUIRED

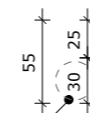

E-02 ELEVATION 02 - FLOATING SHELVES
A160 Scale 1:5 @ A3

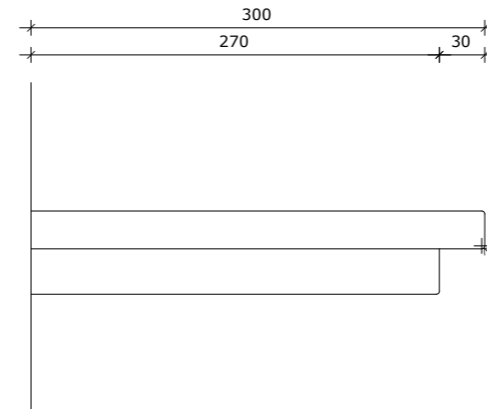

steel bracket 20x20 3mm thick
square hollow

STEEL SUPPORT WITHIN TO
ALLOW SHELVES TO 'FLOAT'.
TO BE SPECIFIED BY JOINER

S-01 SECTION 01 - FLOATING SHELVES
A160 Scale 1:5 @ A3

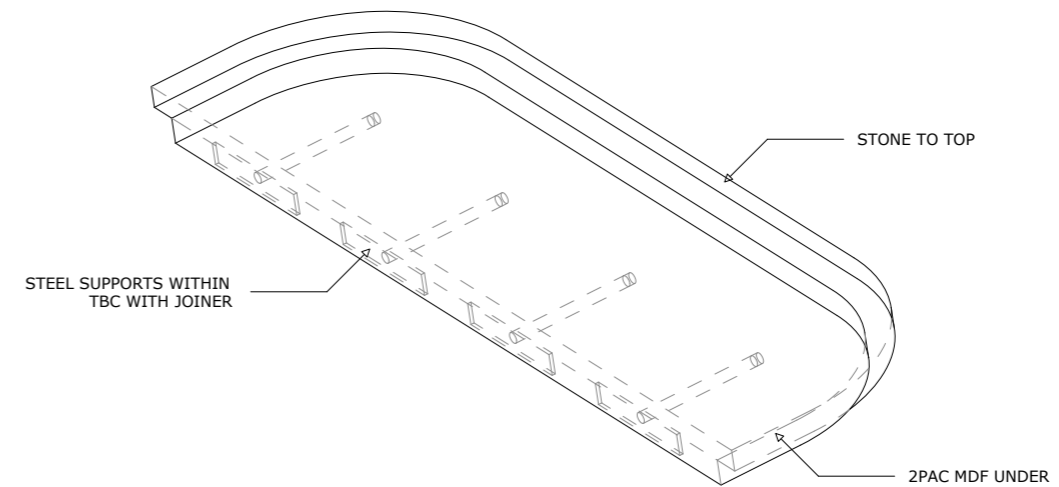
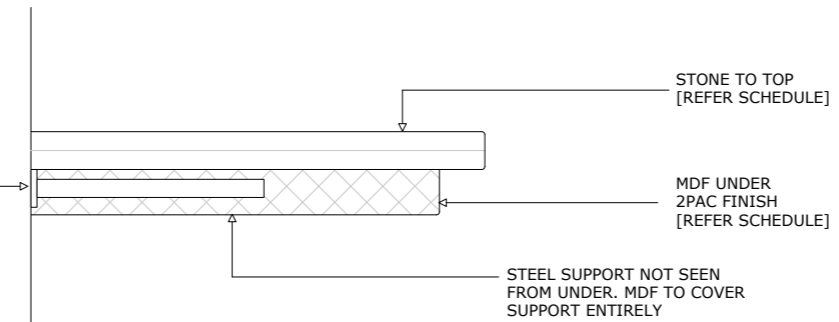

I-01 ISOMETRIC VIEW
NTS

Bree.B

Drawings are for Design Intent and not for construction. Shop drawings must be produced by the joiner for approval by designer and all dimensions verified by all contractors before commencing work. If unsure, always consult with designer before proceeding. All dimensions are in mm unless otherwise stated. Check specifications of ALL appliances and fixtures and only install as per manufacturers instructions.

PROJECT NAME Gordon
ADDRESS 235 Alma Rd, St Kilda East
CLIENT Gordon

DRAWN BY TK
DATE Oct 15, 2024

DWG TITLE CUSTOM SHELVES
SCALE 1:50 @ A3
REVISION

Dwg No.
A160