

	Client: JAKE AND LAUREN WATSON		Door and panels style/colour: BOSTON OAK WOODMATT		Sheet 1 of 2
	Room: BATH	Benchtop Colour: 20MM STONE BY OTHERS		Drawer slides: BLUM ANTARO	Carcass: WHITE HMR
	Date: 07/04/26	Address: 70 PATTERSON ST BON BEACH		Handles Item No: 45' FINGERPULL	Approved by:

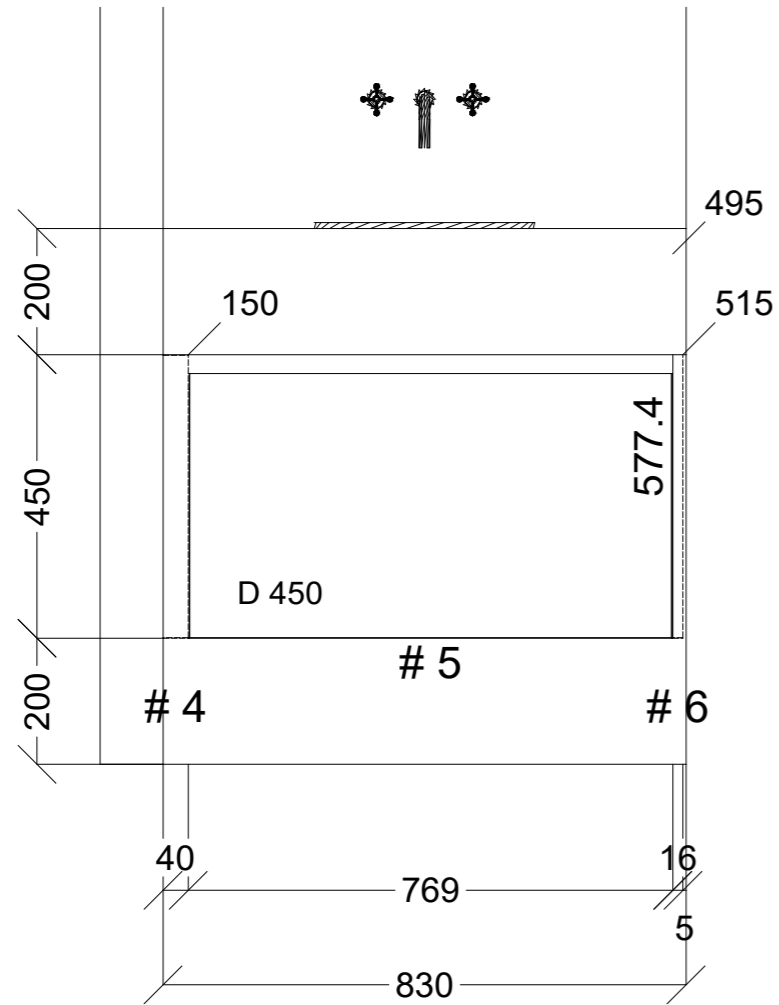
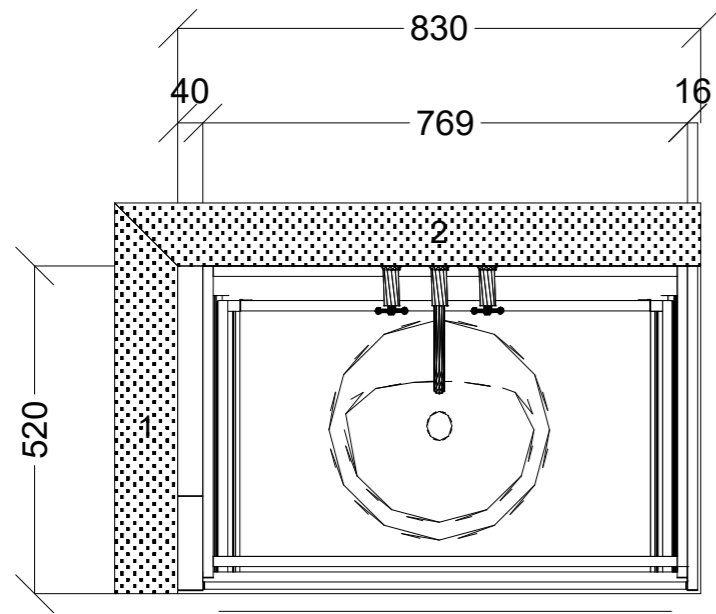

	Client: JAKE AND LAUREN WATSON		Door and panels style/colour: BOSTON OAK WOODMATT		Sheet 2 of 2
	Room: ENSUITE	Benchtop Colour: 20MM STONE BY OTHERS		Drawer slides: BLUM ANTARO	Carcass: WHITE HMR
	Date: 07/04/26	Address: 70 PATTERSON ST BON BEACH	Handles Item No: 45' FINGERPULL		Approved by: